

FOR REFERENCE SEE MAP ENTITLED

1) PROPOSED ADDITION 39 WOOD POND ROAD, WEST HARTFORD, CONN. MAY 24, 1967 1"=50' - JENKINSEN

NOTES:

- 1) PROPERTY LOCATED IN R-10 ZONE.
- 2) Area=23,091 sq. ft. or 0.530 Ac.
- 3) ELEVATIONS BASED ON ASSUMED DATUM.

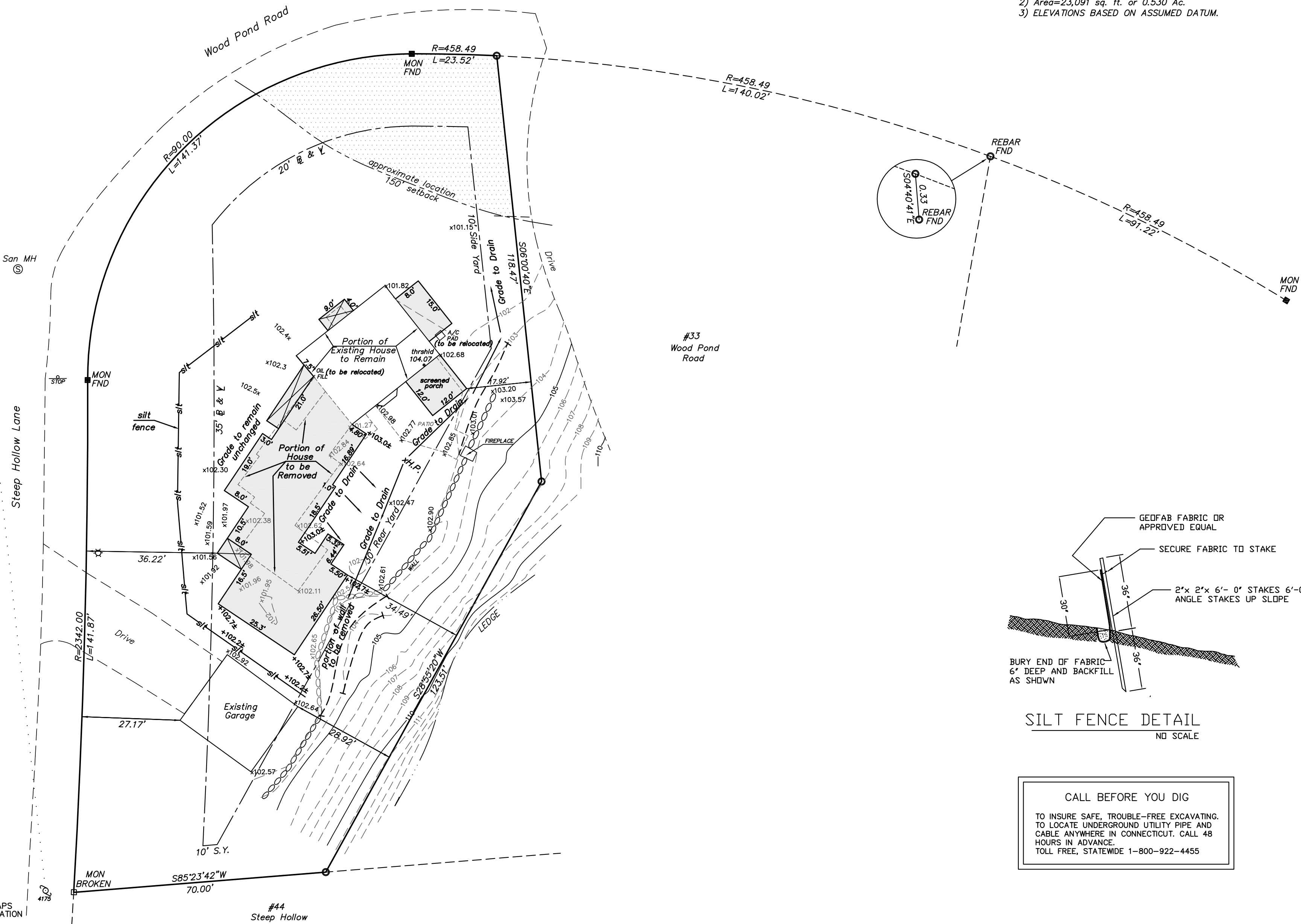

Proposed grade=+000.0±
Existing grade=x000.0

Proposed Addition FIRST FLOOR ELEVATION OF ADDITION TO MATCH EXISTING HOUSE

Portions to be removed or relocated

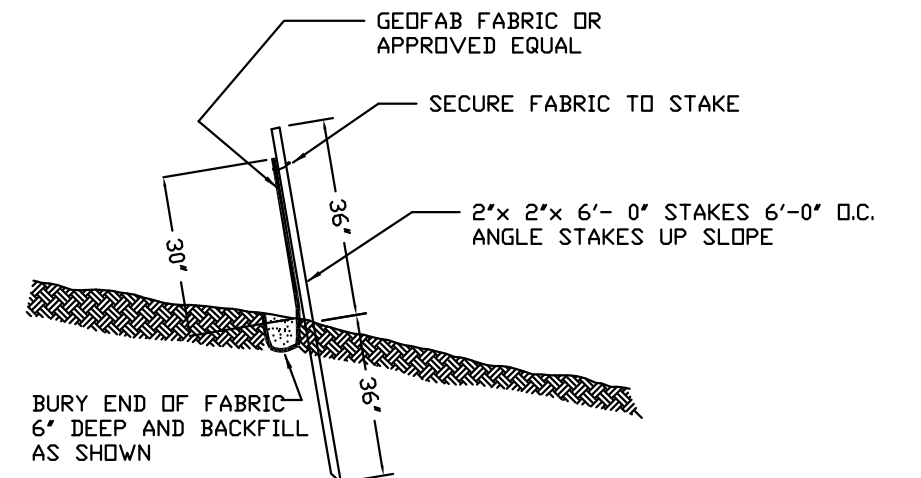

SILT FENCE DETAIL
NO SCALE

CALL BEFORE YOU DIG

TO INSURE SAFE, TROUBLE-FREE EXCAVATING. TO LOCATE UNDERGROUND UTILITY PIPE AND CABLE ANYWHERE IN CONNECTICUT. CALL 48 HOURS IN ADVANCE. TOLL FREE, STATEWIDE 1-800-922-4455

NOTES AND DECLARATIONS
THIS SURVEY AND MAP HAS BEEN PREPARED IN ACCORDANCE WITH THE REGULATIONS OF CONNECTICUT STATE AGENCIES, SECTIONS 20-300b-1 THROUGH 20-300b-20, THE MINIMUM STANDARDS FOR SURVEYS AND MAPS IN THE STATE OF CONNECTICUT ENDORSED BY THE CONNECTICUT ASSOCIATION OF LAND SURVEYORS, INC. THE TYPE OF SURVEY IS PROPERTY SURVEY. THE BOUNDARY DETERMINATION CATEGORY IS RESURVEY AND THE HORIZONTAL ACCURACY CONFORMS TO A-2.

THIS IMPROVEMENT LOCATION MAP CONFORMS TO CLASS A-2 IN ACCORDANCE WITH THE MINIMUM STANDARDS FOR SURVEYS AND MAPS IN THE STATE OF CONNECTICUT AS ADOPTED FOR USE BY THE STATE OF CONNECTICUT ON SEPTEMBER 26, 1996.

TO MY KNOWLEDGE AND BELIEF THIS MAP IS SUBSTANTIALLY CORRECT AS NOTED HEREON.

FRANCIS A. RICHARD, L.S. #11351 SURVEYOR

GRAPHIC SCALE



(IN FEET)
1 inch = 20 ft.

Revised: August 31, 2009
Revised: June 22, 2009

IMPROVEMENT LOCATION SURVEY
Prepared For
Nancy Dean
39 Wood Pond Road
West Hartford, Connecticut
Scale: 1"=20' Date: June 2009
HODGE SURVEYING ASSOCIATES, P.C.
JOB NO. 109-29 DRW.